



MATERIAL EFFECTS ON THRESHOLD COUNTING EFFICIENCY OF TSI MODEL 3785 WATER-BASED CONDENSATION PARTICLE COUNTER

Wei Liu, STANLEY L. KAUFMAN, Gilmore J. Sem, TSI Incorporated, Shoreview, MN
 Frederick R. Quant, Quant Technologies LLC, Blaine, MN

ABSTRACT

The TSI Model 3785 water-based condensation particle counter (WCPC) offers rapid number concentration measurements of airborne ultra-fine particles. Its unique design [1-3] allows this instrument to use water as its condensing fluid. Water is odor-free, non-contaminating, readily-available, and inherently eliminates the water condensation problem seen with alcohols in a humid environment. These advantages make it important to fully characterize its performance in comparison with standard butanol condensation particle counters. One critical aspect of such a counter's performance is its material dependence, i.e., the effect of the material of particles on its threshold response. From the performance of the early General Electric water-based condensation particle detectors [4], it is known that for a water-based particle counter, there will be a difference in response to hydrophobic and hydrophilic materials.

The threshold behavior of the WCPC was measured in this study, for particles of several different materials including hydrophilic sucrose particles, hydrophobic oil particles (emery oil, DOS, and DOP), silver particles, and ambient aerosol. Sucrose and oil particles were generated using an electro-spray aerosol generator (TSI 3480), and silver particles were generated using a tube oven. Monodisperse particles were selected with a nano DMA. The particle counts of the WCPC were compared to the readings of an aerosol electrometer (TSI 3068A) or an ultrafine CPC (TSI 3025A) to obtain its counting efficiencies. The D_{50} cut point, i.e., the size with a 50% counting efficiency, of the WCPC is 4.7 nm for sucrose and ambient aerosols, and 5.6 nm for pure silver particles. The D_{50} cut points for pure oil particles are much larger (> 50 nm) and are different for different types of oils. However, the WCPC can detect much smaller, contaminated, oil particles.

OPERATION PRINCIPLE

- Similar to the conventional butanol-based CPCs, the WCPC also enlarges particles into larger, easily-detectable droplets by condensation
- A new, patented "growth-tube" technology (Aerosol Dynamics Inc. Berkeley CA, Patent No. US 6,712,881) allows the use of water as the working fluid
- Aerosol first enters the cool (20 °C), wetted, saturator section of the growth tube to become saturated with water vapor and temperature equilibrated (Figure 1)
- Sample then passes to the growth section with heated walls (60 °C) that produce an elevated vapor pressure. Water vapor diffuses quickly to the center of the aerosol stream before the aerosol is heated up because the mass diffusivity of water vapor is higher than the thermal diffusivity of air
- Aerosol flow thus becomes supersaturated and water condenses on the particles as the flow passes up the growth tube. The enlarged droplets are then detected by the optical detector

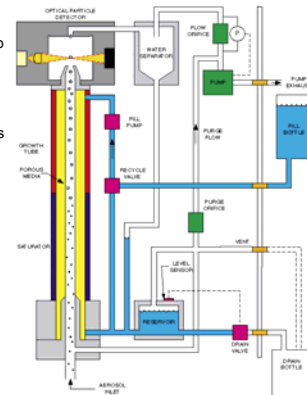

Figure 1
Flow Schematic of the WCPC

TEST SETUP AND RESULTS

Sucrose Particles

- Sucrose particles were generated using an electro-spray and were selected using a nano DMA to produce monodisperse sucrose particles. The test setup is shown in Figure 2
- In the electro-spray, the peak size of particles generated ($D_{particle}$) is mainly determined by the concentration of the sucrose solution (C) based on the following equation:

$$D_{particle} = D_{droplet} \cdot C^{1/2}$$
- where $D_{droplet} \approx 150$ nm, is the size of droplets exiting the 25 μ m ID capillary (Figure 3). The buffer solution used for sucrose is distilled water with 20 millimolar ammonium acetate
- Fifteen particle sizes in the range of 3.2 to 55 nm were tested
- For each particle size, the aerosol was passed alternately through the WCPC and the aerosol electrometer in order to maximize the electrometer readings, assuming that the aerosol concentration generated by the electro-spray was stable. This assumption was verified by switching back to the first tested instrument and checking its readings at the end of each test
- The particle concentration readings of the WCPC were then compared to those of the electrometer (converted from voltage readings, see Figure 4) to obtain the counting efficiency of the WCPC at the specific particle size
- The D_{50} cut point of the WCPC, calculated based on the curve fit equation of the counting efficiency data points, is 4.7 nm for sucrose particles (Figure 6)

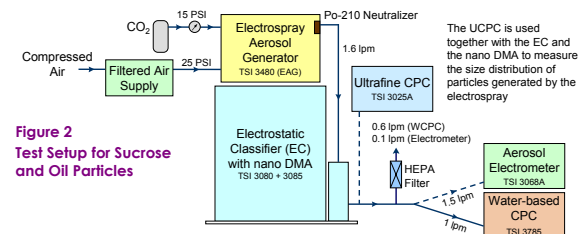

Figure 2
Test Setup for Sucrose and Oil Particles

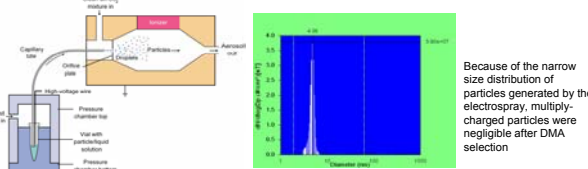

Figure 3 Electro-spray - Flow Schematic and Typical Size Distribution

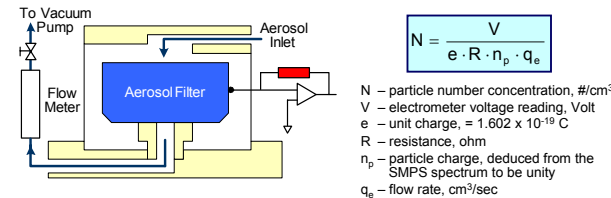

Figure 4 Electrometer
Flow Schematic and Calculation of Particle Number Concentration

Ambient Aerosol

- Ambient aerosol was directly sampled from outdoors and monodisperse particles were selected using a nano DMA as shown in Figure 5
- The sampling location was in the TSI parking lot and was very close to the loading dock (~3 m)
- Because of the very low concentration of monodisperse particles ≤ 10 nm, the WCPC was compared to a TSI 3025A ultrafine CPC (UCPC) instead of an electrometer
- Nine particle sizes in the range of 3 to 50 nm were tested
- The totalizer mode was used for the CPCs at particle sizes ≤ 10 nm because of the low aerosol flow rate of the UCPC (30 cm^3/min) and the low particle concentration. The time duration of each test varied from 2 to 11 hours to minimize the counting statistical error ($< \pm 1\%$ for 5 - 10 nm particles; $< \pm 2\%$ for 4 - 5 nm particles; $< \pm 5\%$ for 3.5 nm particles)
- The counting efficiency curve of the UCPC [5] and the concentration ratios of the WCPC and the UCPC were used to calculate the efficiencies of the WCPC at different particle sizes
- The D_{50} cut point of the WCPC is also about 4.7 nm for ambient aerosol as shown in Figure 6

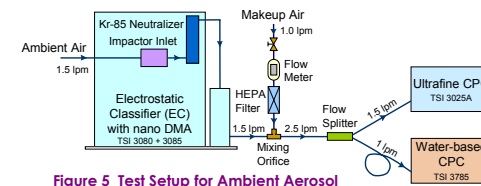

Figure 5 Test Setup for Ambient Aerosol

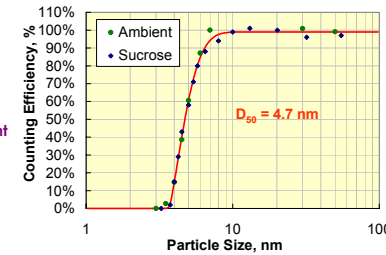

Figure 6
Counting Efficiency Data and Curve Fit for the WCPC with Sucrose Particles and Ambient Aerosol

Oil Particles

- The setup for testing oil particles was the same as the one for sucrose particles (Figure 2). The buffer solution used for oil particles was 50/50 ethanol/isopropanol mixture with 67 millimolar ammonium acetate
- No complete counting efficiency curve (0 to 100%) was obtained for oil particles because the largest particle size generated by the electro-spray was limited by the maximum possible concentration of the oil solutions
- For very pure, lab-generated, DOS and DOP particles, the D_{50} cut point is about 50 to 60 nm as shown in Figure 7
- The emery oil tests demonstrated that the cleanliness of the capillary in the electro-spray had a significant effect on the counting efficiency of the WCPC (Figure 8)
 - Very pure emery oil particles were generated using a capillary that had been used for emery oil for over a month. The WCPC could hardly detect any pure emery oil particles, even at 60 nm
 - "Contaminated" emery oil particles were generated after using the electro-spray for generating sucrose particles. The D_{50} of the WCPC was decreased to 7 nm
 - "Less contaminated" emery oil particles were generated after 24 hours of cleaning of the capillary that was used to generate sucrose particles. The D_{50} of the WCPC became 50 nm

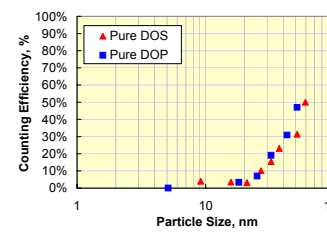
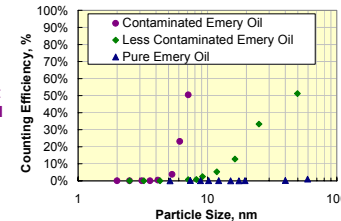

Figure 7
Counting Efficiency Data for the WCPC with DOS and DOP Particles

Counting Efficiency Data for the WCPC with Pure and Contaminated Emery Oil Particles



Silver Particles

- Pure silver (99.999%) was vaporized into a regulated N_2 gas stream in a Scheibel-Porstendörfer aerosol generator [6]. Cold N_2 gas was merged into the flow to quench the vapor to form silver particles by homogeneous nucleation and condensation. These particles were then selected using a nano DMA to produce monodisperse particles. The test setup is shown in Figure 9
- Sixteen particle sizes in the range of 3 to 55 nm were tested
- Multiply-charged particles were negligible ($< 0.2\%$ for 55 nm, $< 0.01\%$ for particles ≤ 20 nm)
- The effect of N_2 on the particle size selected by the DMA was negligible as well
- The D_{50} cut point of the WCPC for silver particles is 5.6 nm as shown in Figure 10

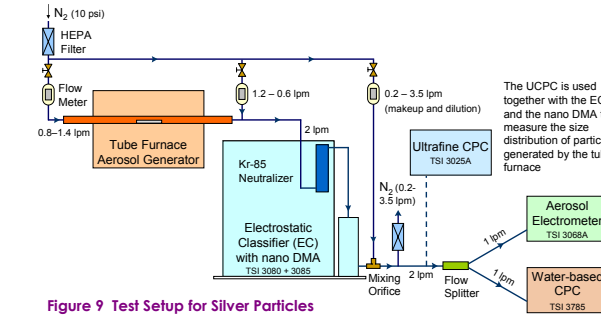

Figure 9 Test Setup for Silver Particles

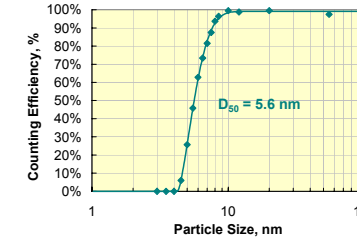
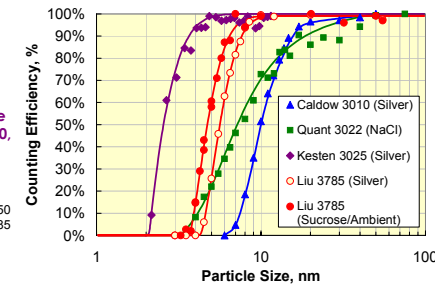

Figure 10
Counting Efficiency Data and Curve Fit for the WCPC with Silver Particles

CPC COUNTING EFFICIENCY COMPARISON (Figure 11)

Figure 11
Comparison of the Counting Efficiency Data and Curves for the Water-based CPC (3785) and the Butanol-based CPCs (3010, 3022, and 3025) [5, 7-9]*



* Data for 3010 and 3022 CPCs was normalized to unity above 50 nm, while data for 3025 and 3785 CPCs was not normalized

CONCLUSIONS

- The TSI Model 3785 water-based CPC offers a new, odor-free solution to particle concentration measurements. As everyone knows, water is readily available and environmentally friendly. Using the WCPC also eliminates the need to worry about water uptake in humid environment
- The WCPC condenses water onto particles making use of the high diffusivity of water vapor. It has a cooled saturator and a heated condenser, working like human lungs breathing in cold air in the winter
- Although the WCPC demonstrates some material dependency during this study, this material dependency is negligible for real life ambient aerosol. For both hydrophilic sucrose particles and ambient aerosol, the WCPC can detect particles as small as 4.7 nm (D_{50}) and the counting efficiency curve rises as sharply as the TSI 3025A ultrafine CPC
- Even for hydrophobic pure silver particles, the WCPC can detect down to 5.6 nm (D_{50}), which is very close to the cut point for sucrose particles and ambient aerosols
- High purity oil droplets were successfully generated using a clean electro-spray and were shown to have a higher threshold diameter for detection in the WCPC. Contamination of these oil particles decreased this threshold diameter.

REFERENCES

- S. V. Hering and M. R. Stolzenburg, Continuous, Laminar Flow Water-based Particle Condensation Device and Method, US Patent 6,712,881, issued March 30, 2004.
- S. V. Hering, M. R. Stolzenburg, F. R. Quant, and D. Oberreit, A Continuous, Laminar Flow, Water-based Condensation Particle Counter. Post-deadline paper presented at American Association for Aerosol Research Annual Conference, Anaheim, CA, October 2003.
- S. V. Hering, M. R. Stolzenburg, F. R. Quant, and D. Oberreit, A Laminar-Flow, Water-based Condensation Particle Counter, submitted to American Association for Aerosol Research Annual Conference, Atlanta, GA, October 2004.
- B. Vonnegut, Method and Apparatus for Measuring the Concentration of Condensation Nuclei, US Patent 2,684,008, issued July 20, 1954.
- J. Kesten, A. Reineking, and J. Porstendörfer, Calibration of a TSI Model 3025 Ultrafine Condensation Particle Counter, *Aerosol Science and Technology* 15:107-111, 1991.
- H. G. Scheibel and J. Porstendörfer, Generation of Monodisperse Ag- and NaCl- Aerosols with Particle Diameters between 2 and 300 nm, *Journal of Aerosol Science*, 14(2):113-126, 1983.
- R. C. Caldow, M. R. Palmer, and F. R. Quant, Performance of the TSI Model 3010 Condensation Particle Counter, paper presented at the American Association for Aerosol Research Eleventh Annual Meeting, San Francisco, California, USA, Oct. 1992 (TSI paper A83).
- F. R. Quant, R. C. Caldow, G. J. Sem, and T. J. Addison, Performance of Condensation Particle Counters with Three Continuous-Flow Designs, *Journal of Aerosol Science*, 23(S1):S405-S408, 1992 (TSI paper A79).
- G. J. Sem, Design and Performance Characteristics of Three Continuous-Flow Condensation Particle Counters: a Summary, *Atmospheric Research*, 62:267-294, 2002.