

# Model 8612 EVERWATCH® Face Velocity Monitor Installation Instructions

**WARNING:** The Model 8612 Face Velocity Monitor must be wired to a 24 VAC or 24 VDC (400 mA) power source. Wiring the unit to 120 VAC will cause serious damage to the unit and void the warranty.

The Model 8612 Velocity Sensor must reference room air. This means that if the fume hood side walls extend to the ceiling, a Model 8691 Fume Hood Sensor Venting Kit must be installed (Figure 7).

The purpose of these instructions is to guide the installer through the installation of the TSI EVERWATCH® Model 8612 Face Velocity Monitor. Please read these instructions thoroughly before beginning installation. The instructions begin with Figure 1 which shows a typical EVERWATCH® monitor installation, followed by a component list, and then some very important installation notes.

The order of installation presented in the instructions is a guideline. The piece parts may be installed in any order.

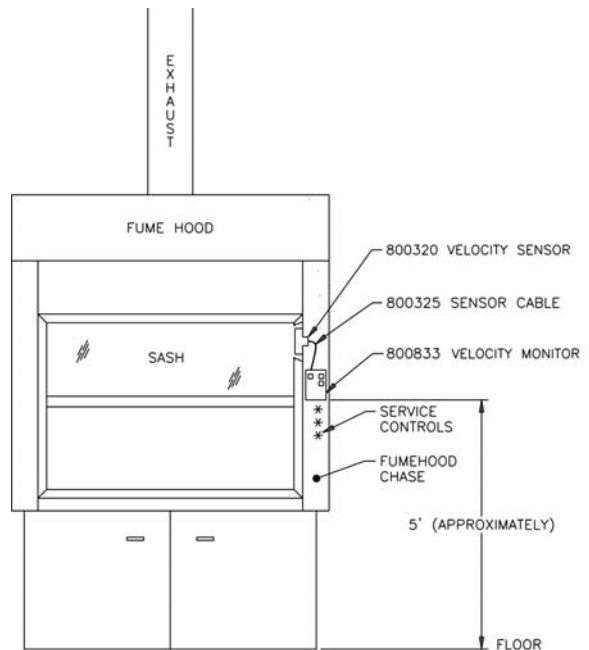

Figure 1: Typical Installation of EVERWATCH® Components

## Component List

Part Number	Qty	Description
800320	1	Velocity Sensor
800325	1	Sensor Cable Assembly
800833	1	Velocity Monitor

EVERWATCH is a registered trademark of TSI Incorporated.



---

---

## Velocity Monitor Rough-In

**WARNING:** The velocity sensor and velocity monitor mount on the same side of the fume hood (Figure 1).

1. Select the mounting location of the VELOCITY MONITOR. The monitor is typically mounted above the service controls (see Figure 1).
2. Cut a hole at this location, sized to mount a standard single gang electrical box.
3. Mount a single gang electrical box.

---

---

## Velocity Sensor Installation

**WARNING:** Do *not* alter the length of the 800325 SENSOR CABLE ASSEMBLY (cable with 4-pin connectors on each end).

800320 VELOCITY SENSOR must be referenced to room air. If the fume hood panel extends to the ceiling, a **Model 8691** Vent Kit must be installed (Figure 7).

1. Determine VELOCITY SENSOR location. Use Figure 2 as a guideline.
2. VELOCITY SENSOR is mounted to liner wall inside hood.
3. Drill 2¼-inch hole through the fume hood liner wall at this location.
4. Install MOUNTING PLATES to fume hood liner wall using 2 of the 8-32 x 5/8 inch screws provided. The MOUNTING PLATES must be configured as shown in Figure 3.
5. Plug SENSOR CABLE ASSEMBLY into the VELOCITY SENSOR.
6. Thread the SENSOR CABLE ASSEMBLY through the mounting plates down to the VELOCITY MONITOR electrical rough-in box (Figure 4). The space between the fume hood liner wall and outer sheet metal panel works well as a chase. Leave 8 inches of slack at the VELOCITY MONITOR end (**DO NOT CUT SENSOR CABLE LENGTH**).
7. Mount the VELOCITY SENSOR to the MOUNTING PLATE using the remaining two 8-32 x 5/8 inch screws provided (Figure 4).
8. The mounted VELOCITY SENSOR should look like Figure 4.

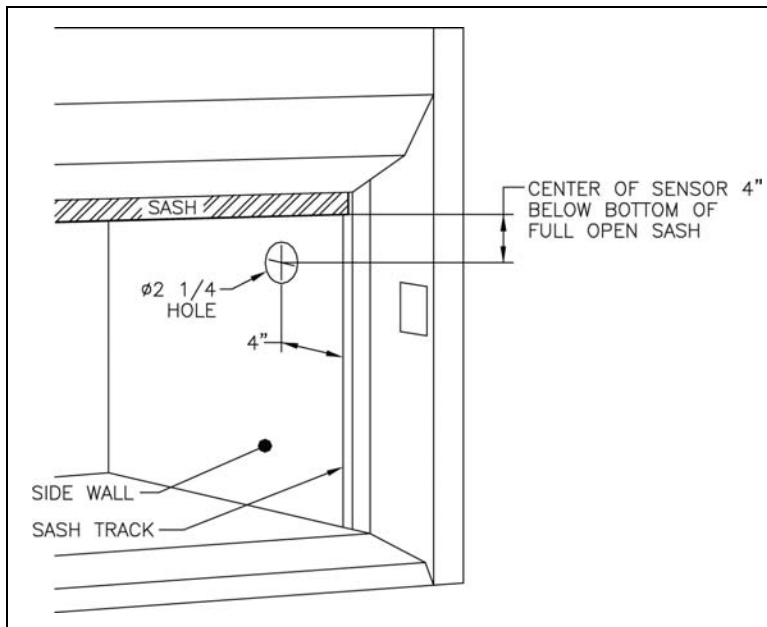

Figure 2: Velocity Sensor Location

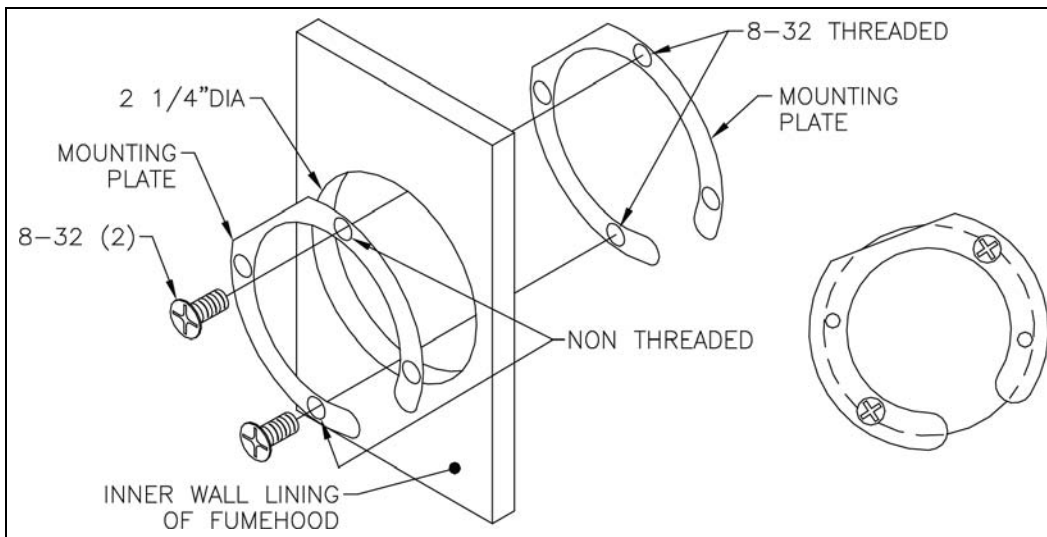

Figure 3: Mounting Plates

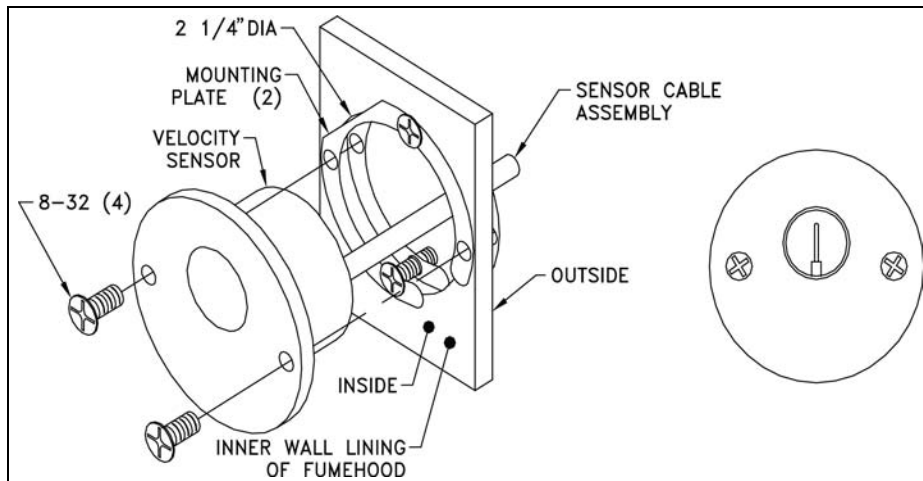

Figure 4: Mounted Velocity Sensor

## Velocity Monitor Installation

1. Attach mounting bracket to single gang electrical box.
2. Remove the connectors from the back of the VELOCITY MONITOR.

**WARNING:** MONITOR must be wired exactly as wiring diagram shows. Making modifications to the wiring may severely damage unit.

3. Plug the connectors into the VELOCITY MONITOR.
4. Plug sensor cable assembly into the VELOCITY MONITOR.
5. EVERWATCH<sup>®</sup> Monitor is attached to mounting bracket by sliding top of controller down on bracket and then snapping in bottom of controller case. The bottom mounting tab goes inside the monitor box.
6. Attach the monitor to the bottom of the mounting bracket using the 3/8-inch, #8 sheet metal screw (Figure 5).

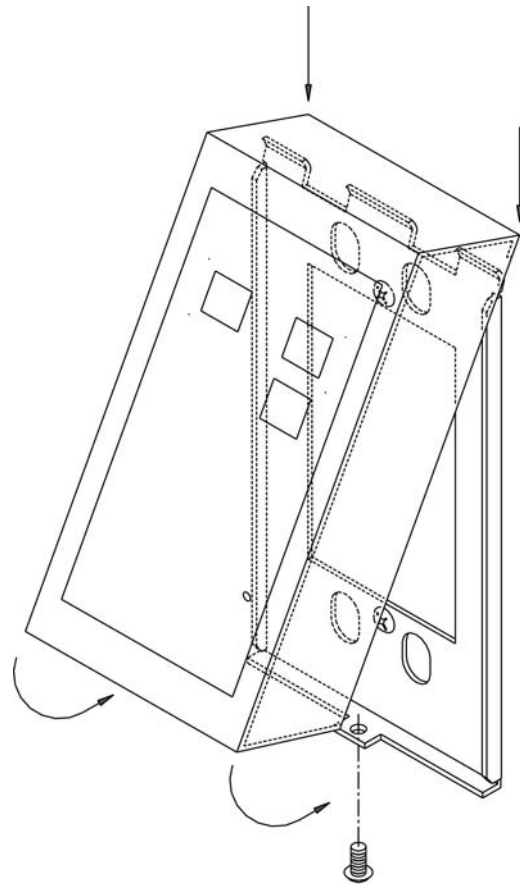
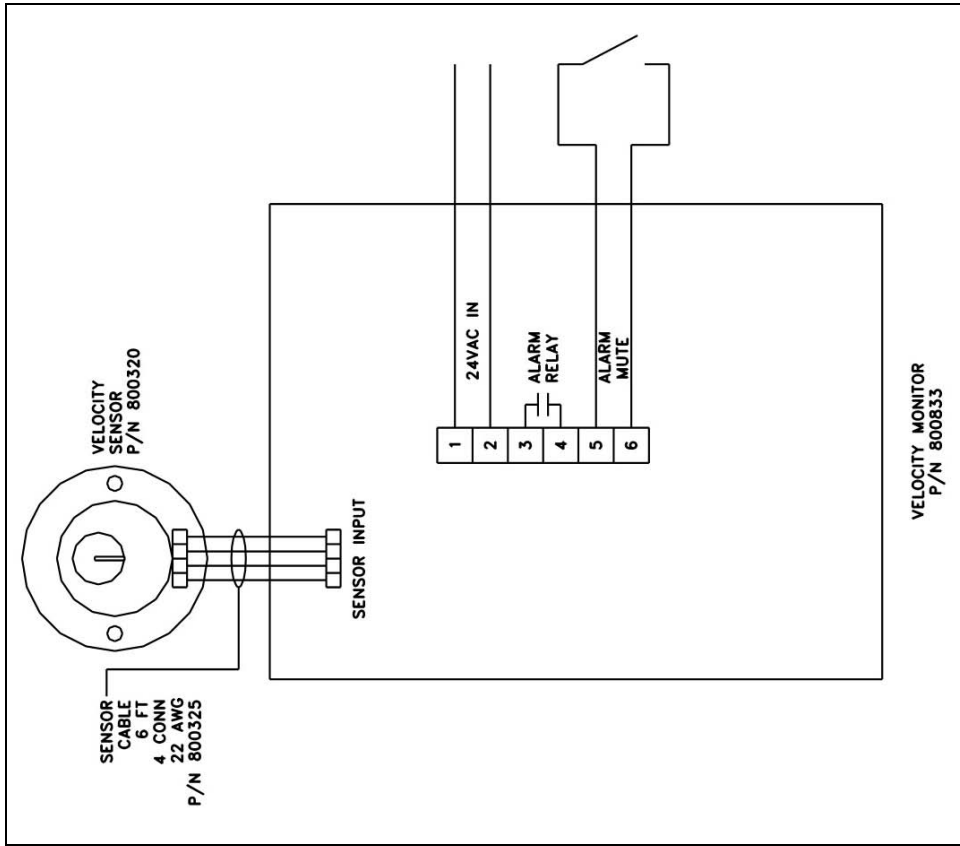

Figure 5: Mounting Monitor to Bracket



**WARNING:** Do *not* connect more than 24 VAC to any terminal. Ensure proper polarity when connecting more than one monitoring device per transformer.

Figure 6: Wiring Velocity Monitor

---

## Calibration

1. Adjust fan speed, balancing damper, and/or sash position until face velocity is at desired alarm value.
2. Using tool provided, turn the screw on the front of the EVERWATCH® monitor until alarm is activated. Turn the screw clockwise to increase the alarm set point, and counter-clockwise to decrease the alarm set point.
3. Reset fan speed and balancing damper to final position for desired exhaust flow from hood.

---

## Vent Kit

A Model 8691 vent kit is required if the fume hood side walls extend to the ceiling in order to reference the velocity sensor to room air.

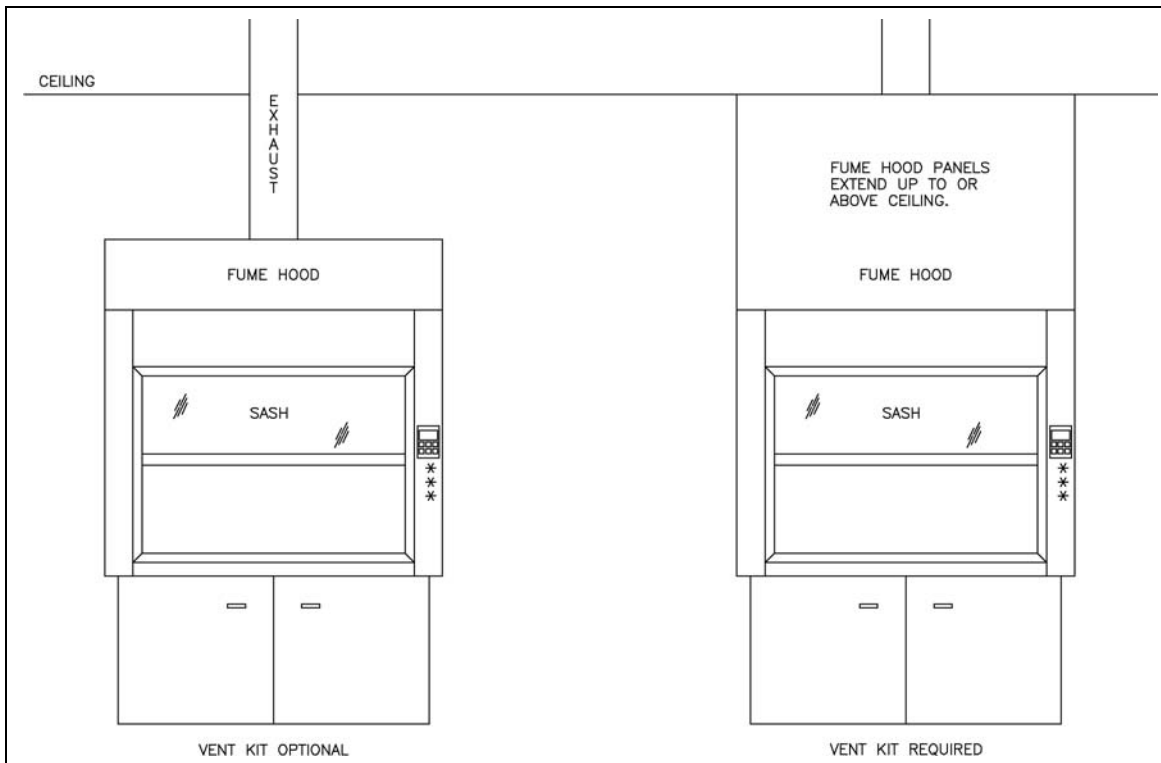

Figure 7: Fume Hood Sensor Venting Kit

This concludes installation of the monitor. If you need assistance installing the system, call TSI Customer Service at 651-490-2811 or 800-874-2811.

---

TSI Incorporated – 500 Cardigan Road, Shoreview, MN 55126 U.S.A

USA	Tel: +1 800 874 2811	E-mail: <a href="mailto:answers@tsi.com">answers@tsi.com</a>	Website: <a href="http://www.tsi.com">www.tsi.com</a>
UK	Tel: +44 149 4 459200	E-mail: <a href="mailto:tsiuk@tsi.com">tsiuk@tsi.com</a>	Website: <a href="http://www.tsiinc.co.uk">www.tsiinc.co.uk</a>
France	Tel: +33 491 11 87 64	E-mail: <a href="mailto:tsifrance@tsi.com">tsifrance@tsi.com</a>	Website: <a href="http://www.tsiinc.fr">www.tsiinc.fr</a>
Germany	Tel: +49 241 523030	E-mail: <a href="mailto:tsigmbh@tsi.com">tsigmbh@tsi.com</a>	Website: <a href="http://www.tsiinc.de">www.tsiinc.de</a>
India	Tel: +91 80 41132470	E-mail: <a href="mailto:tsi-india@tsi.com">tsi-india@tsi.com</a>	
China	Tel: +86 10 8251 6588	E-mail: <a href="mailto:tsibeijing@tsi.com">tsibeijing@tsi.com</a>	
Singapore	Tel: +65 6595 6388	E-mail: <a href="mailto:tsi-singapore@tsi.com">tsi-singapore@tsi.com</a>	



TRUST. SCIENCE. INNOVATION.

Contact your local TSI Distributor or visit our website [www.tsi.com](http://www.tsi.com) for more detailed specifications.