

Model 8610 EVERWATCH® Face Velocity Monitor Installation Instructions—U.S.

WARNING: The Model 8610 Face Velocity Monitor must be wired to the 24 VAC transformer provided. If multiple units are wired to a master transformer, each unit must have an isolation transformer installed. Wiring the unit to 120 VAC will cause serious damage to the unit and void the warranty.

The Model 8610 Velocity Sensor must reference room air. This means that if the fume hood side walls extend to the ceiling, a Model 8691 Fume Hood Sensor Venting Kit must be installed (Figure 7).

The purpose of these instructions is to guide the installer through the installation of the TSI EVERWATCH® Model 8610 Face Velocity Monitor. Please read these instructions thoroughly before beginning installation. The instructions begin with Figure 1 which shows a typical EVERWATCH® installation, followed by a component list, and then some very important installation notes.

The order of installation presented in the instructions is a guideline. The piece parts may be installed in any order.

Component List

Part Number	Qty	Description
800320	1	Velocity Sensor
800325	1	Sensor Cable Assembly
Found on back of monitor	1	Velocity Monitor
800420	1	Transformer
800414	1	Transformer Cable

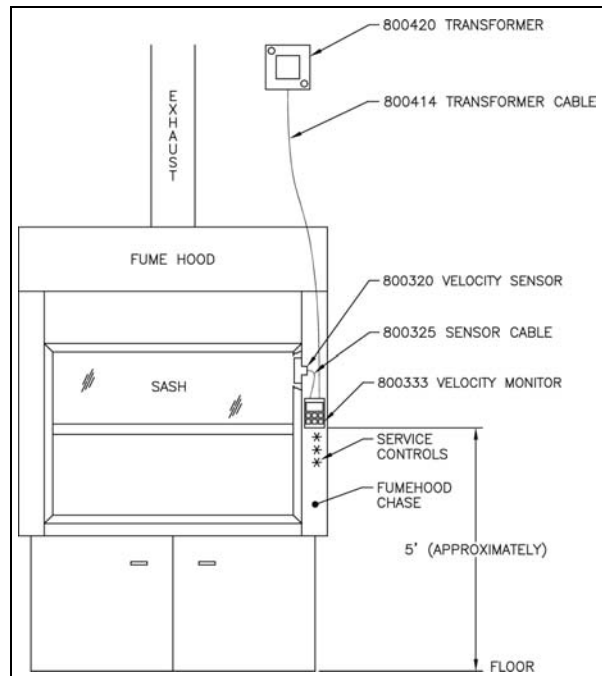

Figure 1: Typical Installation of EVERWATCH® Components

EVERWATCH® is a registered trademark of TSI Incorporated.



Velocity Monitor Rough-In

WARNING: The velocity sensor and velocity monitor mount on the same side of the fume hood (Figure 1).

1. Select the mounting location of the VELOCITY MONITOR. The monitor is typically mounted above the service controls (see Figure 1).
2. Cut a hole at this location, sized to mount a standard single gang electrical box.
3. Mount a single gang electrical box.
4. Determine VELOCITY SENSOR location. Use Figure 2 as a guideline.
5. VELOCITY SENSOR is mounted to liner wall inside hood.
6. Drill 2¼-inch holes through the fume hood liner wall at this location.

Velocity Sensor Installation

WARNING: Do **not** alter the length of the 800325 SENSOR CABLE ASSEMBLY (cable with 4-pin connectors on each end).

800320 VELOCITY SENSOR must be referenced to room air. If the fume hood panel extends to the ceiling, a **Model 8691** Vent Kit must be installed (Figure 7).

1. Install MOUNTING PLATES to fume hood liner wall using 2 of the 8-32 × 5/8-inch screws provided. The MOUNTING PLATES must be configured as shown in Figure 3.
2. Plug SENSOR CABLE ASSEMBLY into the VELOCITY SENSOR.
3. Thread the SENSOR CABLE ASSEMBLY through the mounting plates down to the VELOCITY MONITOR electrical rough-in box (Figure 4). The space between the fume hood liner wall and outer sheet metal panel works well as a chase. Leave 8 inches of slack at the VELOCITY MONITOR end (**DO NOT CUT SENSOR CABLE LENGTH**).
4. Mount the VELOCITY SENSOR to the MOUNTING PLATE using the remaining two 8-32 × 5/8-inch screws provided (Figure 4).
5. The mounted VELOCITY SENSOR should look like Figure 4.

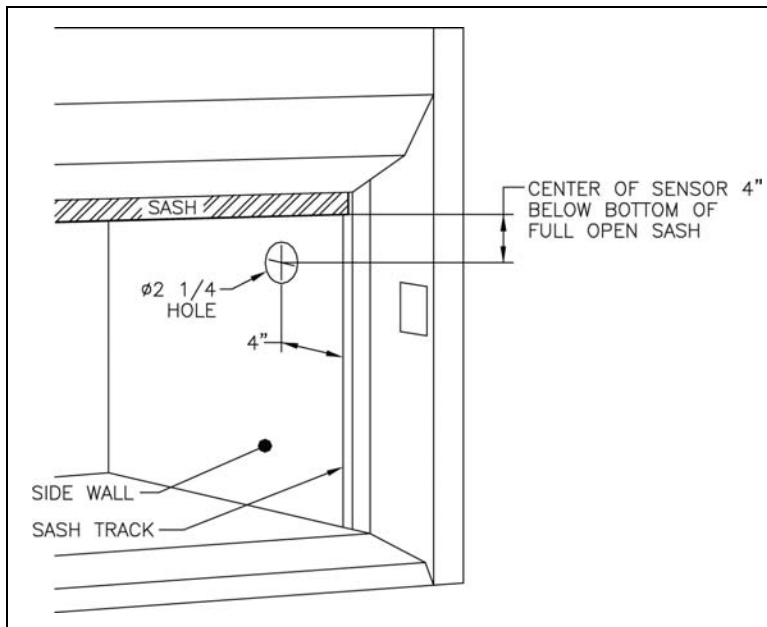

Figure 2: Velocity Sensor Location

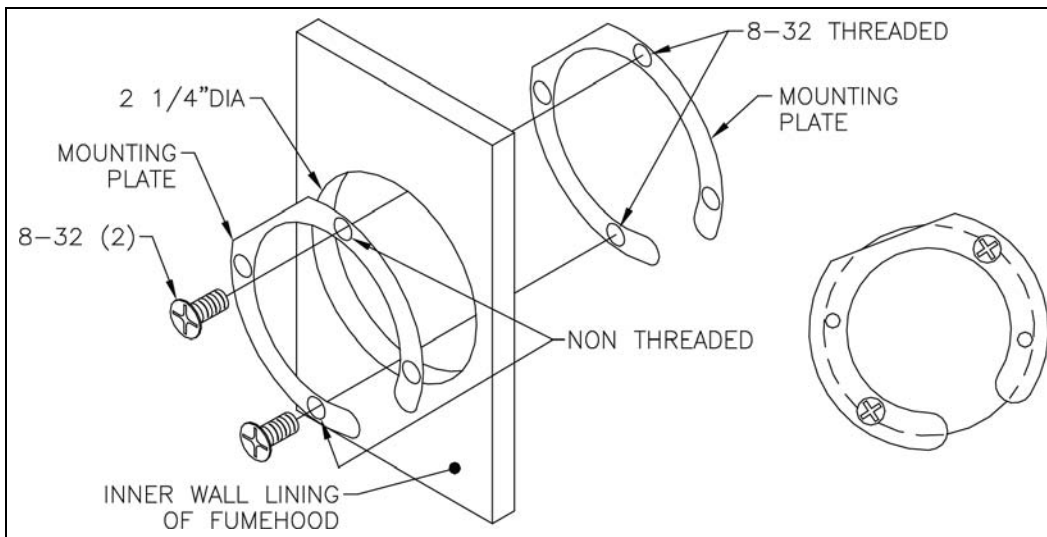

Figure 3: Mounting Plates

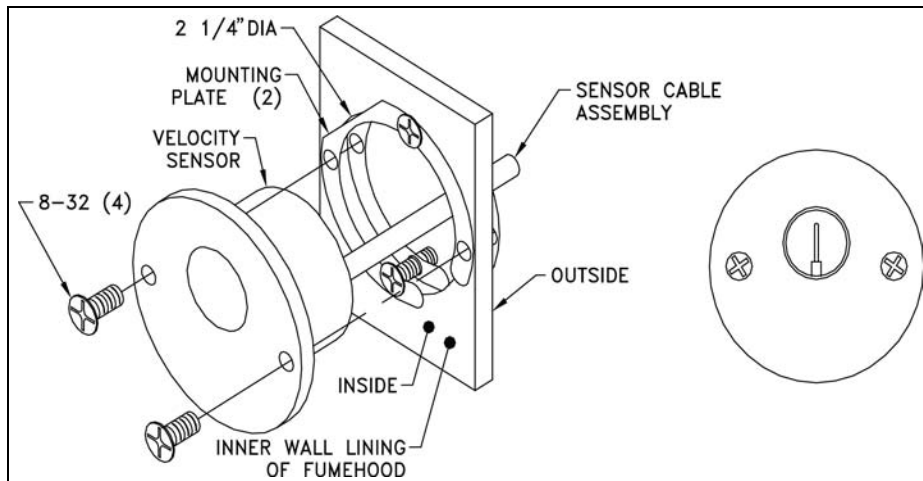

Figure 4: Mounted Velocity Sensor

24 VAC Transformer

WARNING: Make sure no power is applied until all wiring is complete.

Follow all applicable electrical codes, and have qualified personnel install the transformer.

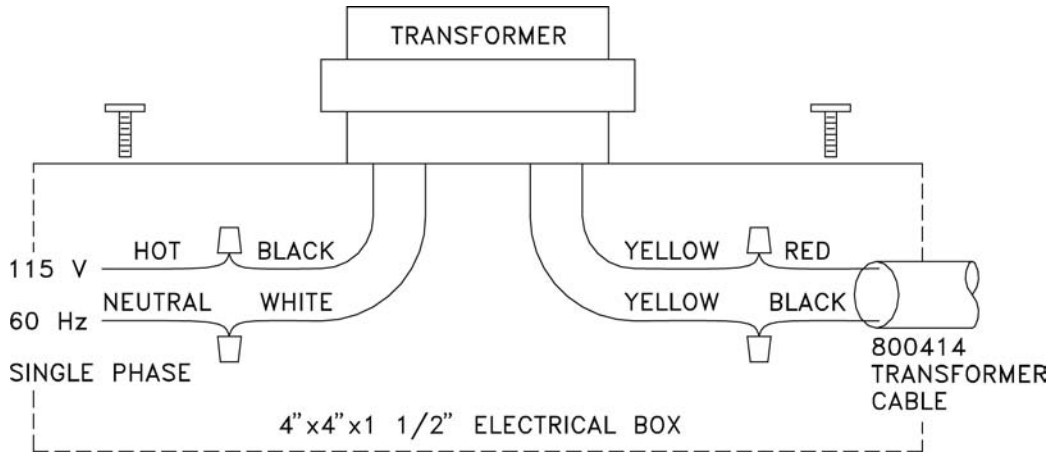

Figure 5: Transformer Installation

NOTE: 120 Volt, single-phase, 60 Hertz power source is required to power the 800420 TRANSFORMER. If TSI Transformer is not installed, a regulated 24 volt, single-phase, 60 Hertz power source is required to power the monitor. If multiple units are wired to a master transformer, an isolation transformer must be installed for each monitor.

1. Mount a standard 4" x 4" x 1 1/2" electrical box, at a convenient location within 20 feet of VELOCITY MONITOR (typically on the wall behind the fume hood).
2. Run 120 Volt, single-phase, 60 hertz line voltage (120 VAC) to electrical box. Follow all applicable electrical codes.
3. Connect 120 VAC line voltage HOT wire to BLACK wire on TRANSFORMER and NEUTRAL wire to WHITE wire on TRANSFORMER. Connect the RED wire on 800414 TRANSFORMER CABLE to either YELLOW wire on the TRANSFORMER and the BLACK wire to the remaining YELLOW wire. Screw the TRANSFORMER to the electrical box.
4. Run TRANSFORMER CABLE from the TRANSFORMER electrical box to the VELOCITY MONITOR electrical box. Have at least 8 inches of cable coming out of the VELOCITY MONITOR rough-in box before trimming cable to length.

Velocity Monitor Installation

1. Remove 10-pin connector from the back of VELOCITY MONITOR.
2. Refer to the wiring diagram (Figure 6) for proper wiring installation. If additional options need to be wired, refer to building prints for proper wiring diagram.
3. Plug the 10-pin and sensor connectors into the monitor.
4. Carefully push the wires into the electrical Box and mount the monitor electronics. Insert the two screws, with lock washers, into the holes on the VELOCITY MONITOR. Screw unit snug to hood ensuring a good ground between monitor, screws, and fume hood.

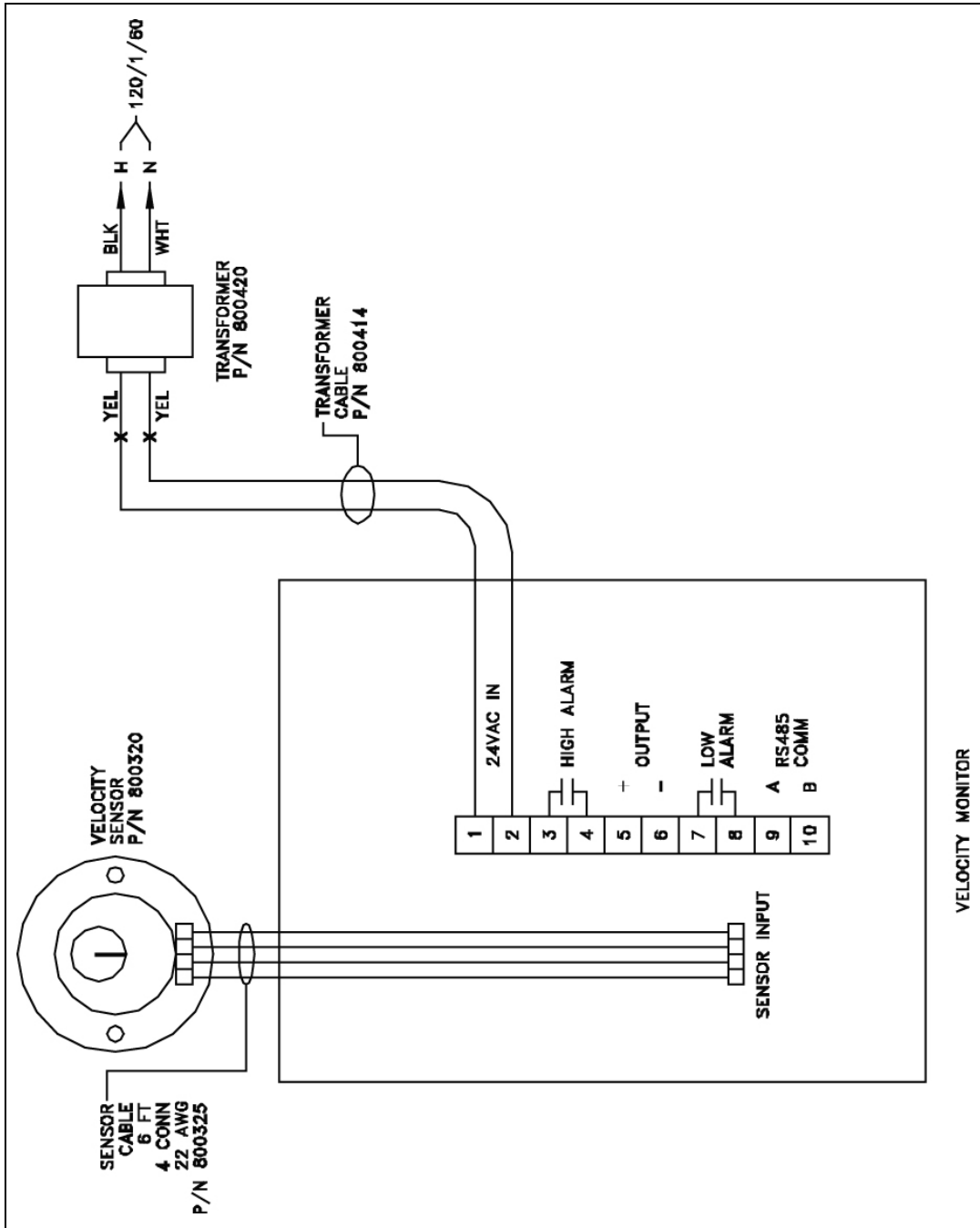

WARNING: Do **not** connect more than 24 VAC to any terminal. Do **not** connect more than one monitoring device per transformer.

Do **not** apply voltage to the RS-485 or analog output. Severe damage may occur to the unit if voltage is applied. This voids the warranty.

Figure 6: Wiring Velocity Monitor

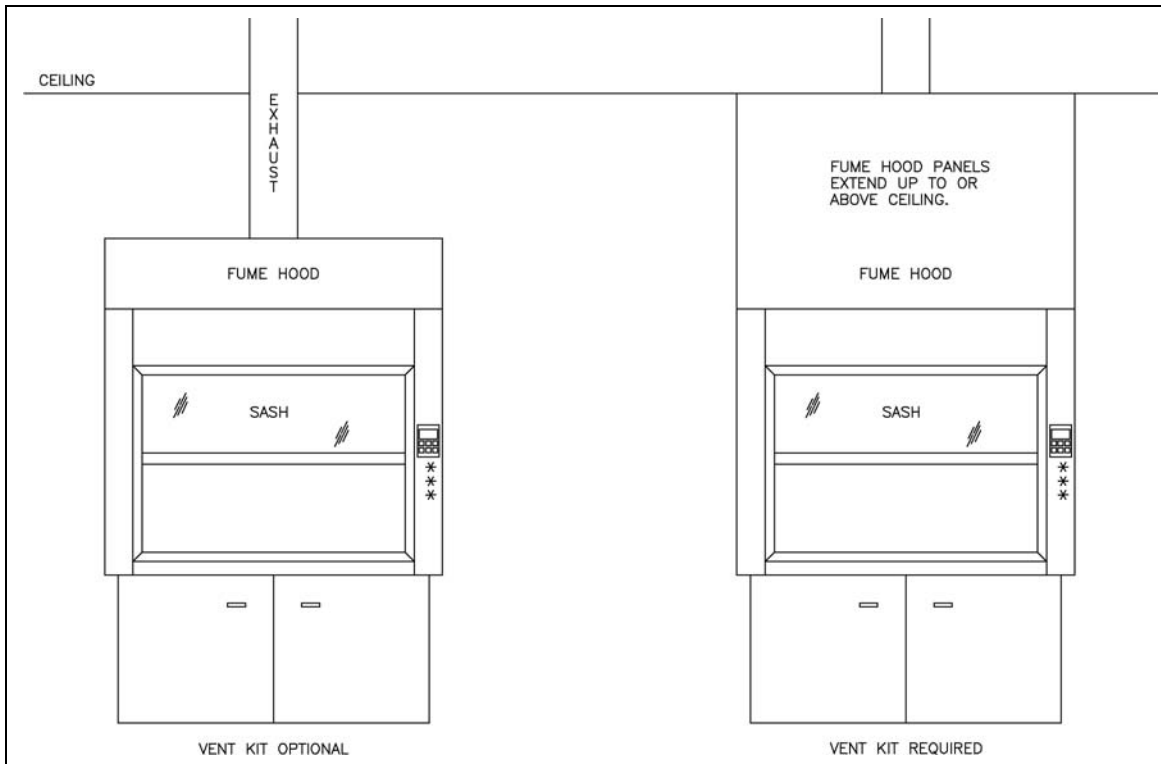

Figure 7: Fume Hood Sensor Venting Kit

If you need assistance installing the system, call TSI Customer Service at 651-490-2811 or 800-874-2811.

TSI Incorporated – 500 Cardigan Road, Shoreview, MN 55126 U.S.A

USA	Tel: +1 800 874 2811	E-mail: answers@tsi.com	Website: www.tsi.com
UK	Tel: +44 149 4 459200	E-mail: tsiuk@tsi.com	Website: www.tsiinc.co.uk
France	Tel: +33 491 11 87 64	E-mail: tsifrance@tsi.com	Website: www.tsiinc.fr
Germany	Tel: +49 241 523030	E-mail: tsigmbh@tsi.com	Website: www.tsiinc.de
India	Tel: +91 80 41132470	E-mail: tsi-india@tsi.com	
China	Tel: +86 10 8251 6588	E-mail: tsibeijing@tsi.com	
Singapore	Tel: +65 6595 6388	E-mail: tsi-singapore@tsi.com	



TRUST. SCIENCE. INNOVATION.

Contact your local TSI Distributor or visit our website www.tsi.com for more detailed specifications.