

Percent Outdoor Air (%OA) Calculation and Its Use

Application Note TI-138

TSI's IAQ-CALC™ Indoor Air Quality Meter and TH-CALC™ Thermo hygrometer calculate Percent Outdoor Air (%OA). In order to take advantage of this feature, it is important to first understand what % Outdoor Air is, why it is important, and how to use these instruments to calculate %OA.

Discovery of Need for Fresh Outdoor Air

In the 1970s, energy consumption was a serious concern and every step was taken to reduce energy use and energy costs. Economizers became popular during this time because they re-circulated valuable conditioned air in the summer and the winter when heating or cooling costs were high.

While this was going on, building designers were designing new buildings to be more efficient by sealing windows and doors better and by sealing other leaky spots. This reduced the amount of infiltration, which is how the majority of outdoor air entered these buildings. This appeared to make the buildings more efficient because heating and cooling costs were reduced.

However, it wasn't until years after these changes were made that the HVAC industry began to notice a trend in these airtight buildings with economizers. Occupants complained of headaches and nauseous feelings. Shutting off the outdoor air intake and sealing the building resulted in an insufficient amount of outdoor air to dilute indoor contamination. This led to Sick Building Syndrome and other Indoor Air Quality complaints.

The Importance of Fresh Outdoor Air

Perhaps the somewhat infamous quote, "The Solution to Pollution is Dilution," may sum up the whole idea behind the importance of fresh outdoor air. We may not go as far as to say that indoor environments have "pollution," but we might want to consider the effects of the indoor air components that can't be filtered out. These include CO₂, body odors, chemicals from photocopiers and cleaners, and so on. Most of these components alone wouldn't make someone sick over short periods of time. However, after long periods of exposure, like in a workplace where 40-hour workweeks are typical, these components have the capacity to make occupants tired, nauseous, and otherwise not as healthy. Eventually, these air components can wear down a person's immune system and can eventually make occupants sick.

The best way to minimize these bad air components is to dilute them with adequate fresh air. This will probably never completely remove the contaminants, but rather, it will keep the components at a level low enough as not to affect occupants.

These days economizers still exist, but they have evolved to recirculate as much conditioned air as possible and still deliver at least the minimum amount of fresh outdoor air recommended by ASHRAE.

ASHRAE 62 Recommendations

ASHRAE, the American Society of Heating, Refrigerating and Air-Conditioning Engineers, Inc., has a standard called ASHRAE 62 “Ventilation for Acceptable Indoor Air Quality.” This standard recommends a minimum amount of fresh air per person for defined spaces. For example, the minimum amount of fresh outdoor air recommended for office spaces is 20 CFM/person*.

Volume of Fresh Outdoor Air

One method used to calculate the volume of fresh outdoor air entering a system is to take a duct traverse of the outdoor air duct intake. However, this is not always feasible, because there may not be sufficient straight ducting to do a good duct traverse¹ of either the return air or the outdoor air. Often, there is not even a duct for outdoor air, so it is essentially impossible to determine the volume of outdoor air that is entering the system.

For an alternative way to determine how much fresh outdoor air is entering a space, use the following equation:

$$\text{Volume Fresh Outdoor Air} = \text{Volume of delivered air} \times \% \text{ Outdoor Air of delivered air}$$

The volume of fresh outdoor air entering a space equals the volume of delivered air (ft³/min, m³/hr, m³/min or L/s) times the % outdoor air. Let’s look at each of these items separately.

Total Volume of Delivered Air

The total volume of delivered air is the total volume of both outdoor air and return air entering a space. To determine the total volume of supply air entering a building, do a duct traverse using a VELOCICALC[®] Plus Rotating Vane Anemometer or a DP-CALC[™] Micromanometer right after the Air Handling Unit and before the duct branches off. Another method to determine the total volume of delivered air is to use the ACCUBALANCE[®] Air Capture Hood at each supply diffuser and to take the sum of the readings.

Percent Outdoor Air

Percent outdoor air is the % of the total volume of delivered air that is outdoor air. There is more than one way to measure %OA. One method is to use a tracer gas like SF₆. This gas would be used to saturate the system at a set concentration and to record how the concentration decreases over time. Using this information, one can figure out what the %OA is. This can also be done with CO₂ if the concentration is high enough and there are no occupants.

Perhaps a better option is to take three readings of CO₂ concentration and plug them into an equation. The three reading locations include outdoor air, supply air, and return air. Another option is to take temperature readings at those same three locations and use a similar equation. This Application Note describes these last two methods of determining %OA.

*As of December, 2000, ASHRAE’s recommendation for minimum amount of fresh outdoor air for office spaces is 20 CFM/person. These recommendations may change over time and are different for different defined spaces including smoking areas, restrooms, and many more. Please refer to the most current ASHRAE 62 guideline for minimum outdoor air recommendations for your specific Application.

Introducing the Equation

To calculate the %OA, use the following equation for CO₂ or temperature:

$$\%OA = \frac{(X_R - X_S)}{(X_R - X_O)} \times 100\%$$

Where:

X_R = **Return** air CO₂ concentration OR temperature
 X_S = **Supply** air CO₂ concentration OR temperature
 X_O = **Outdoor** air CO₂ concentration OR temperature

Some Examples

Let's look at an example. An industrial hygienist takes three samples with the following values:

Outdoor air CO₂ level = X_O = 400 ppm

Supply air CO₂ level = X_S = 645 ppm

Return air CO₂ level = X_R = 823 ppm

$$\text{Then } \%OA = \frac{(X_R - X_S)}{(X_R - X_O)} \times 100\% = \frac{(823 - 645)}{(823 - 400)} \times 100\% = \frac{(178)}{(423)} \times 100\% = 42.1\%$$

And we can try this equation out using temperature measurements, too. Let's say that these measurements are taken in cold climates in the winter:

Outdoor air temperature = X_O = 35 °F

Supply air temperature (before conditioning) = X_S = 55 °F

Return air temperature = X_R = 70 °F

$$\text{Then } \%OA = \frac{(X_R - X_S)}{(X_R - X_O)} \times 100\% = \frac{(70 - 55)}{(70 - 35)} \times 100\% = \frac{15}{35} \times 100\% = 42.9\%$$

And we can try out the equation using summer temperature measurements as well:

Outdoor air temperature = X_O = 93 °F

Supply air temperature (before conditioning) = X_S = 81 °F

Return air temperature = X_R = 70 °F

$$\text{Then } \%OA = \frac{(X_R - X_S)}{(X_R - X_O)} \times 100\% = \frac{(70 - 81)}{(70 - 93)} = \frac{(-11)}{(-23)} = 47.8\%$$

Where To Take Measurements

To make sure the %OA measurement is done properly, the readings need to be taken at the appropriate locations. Outdoor air should always be taken away from the building exhaust vents. The location for supply and return may vary if the %OA value you are interested in getting is from using CO₂ or temperature.

For CO₂, the return air reading should be taken inside the return duct or well before the air mixes with the outdoor air. These locations ensure a stable reading. The supply reading should be taken inside the supply duct.

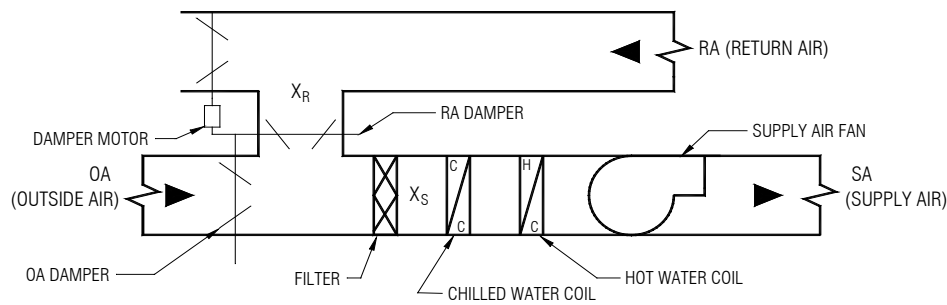

Illustration 1: Air Handling Unit Schematic

If temperature is the measurement used, then the return air value should be taken as close to the air handling unit as possible before the air is mixed with outdoor air. In the illustration given, the return air temperature (X_R) would best be taken in the return air duct just upstream of the return air damper. The supply air should be measured before the air has been conditioned. Temperature measurements should also be taken before any fans, since a fan can increase the temperature up to a few degrees. In the illustration given, the supply air temperature (X_S) would best be taken between the filter and the chilled water coil.

Equation Errors

If the equation results in a negative percentage or a percent above 100%, then this is an equation error. If the supply air value does not fall between the return air value and the outdoor air value, then an error will occur. Typically, if all three measurements are retaken, the issue will resolve itself. If not, then consider which of the following might apply to the situation:

If using temperature to calculate %OA:

- Air has been conditioned before measurement—take measurement closer to the air handling unit.
- Supply air has been mixed with room air—take supply measurement closer to diffuser or inside duct.
- Return air has not been mixed enough—take return air measurement in duct to assure proper mixing.
- Outdoor and inside temperatures are too close to one another—use CO₂ values as a base for %OA calculations.

If using CO₂:

- Supply air is mixing with room air—take measurement closer to diffuser or inside supply duct.
- Return air is not mixed well—take measurement inside return duct.
- Outdoor air measurement is tainted—make sure air entering outdoor air intake is fresh and clean.
- Not enough occupants to generate CO₂—use temperature values as a base for %OA calculations.

Procedures For % Outdoor Air Calculation:

When using a TSI IAQ-CALC™ or TH-CALC™ meter, the general procedure is to take a sample in each of four modes. The modes are return air, outdoor air, supply air, and %OA. Pressing the **SAMPLE** key while in %OA mode will store all four sample values. You may use the ▲ and ▼ keys to move from mode to mode.

Press **TEMP** or **CO₂** at any time to move from calculating %OA from **TEMP** to **CO₂** or from **CO₂** to **TEMP**. You may press the **%OA** key at any time to exit back to normal sampling. Details on the procedure are as follows:

Note: You may press the %OA key at any time during the following procedure to exit without saving any data and to return to normal sampling.

Press the %OA key once to put the instrument in **return mode**. The IAQ-CALC™ meter defaults to measuring %OA using CO₂ readings. To calculate %OA using temperature, press the TEMP key.

Note: The TEMP key may be pressed at any time during this procedure to begin using temperature for the %OA calculation.

In **return air** mode, “RETURN” will appear on the display. The current temperature or CO₂ value will display on the bottom line of the display. Previously taken values will display on the top line, or if this is the first time this mode has been used, “----” will display on the top line.

Note: Do not breathe on the probe at any time during this process. CO₂ concentrations in the breath are very high and this could significantly alter the results.

Insert the probe into the return air duct, then press the SAMPLE key to take a sample once the reading has stabilized. Now the sampled value will display on the top line. If the sample is not acceptable or the reading is not yet stable, wait a minute and take another sample to overwrite the value on the top line. Once the top line value is acceptable, press the ▲ key to advance to outdoor air mode.

Proceed to an outdoor location for the outdoor air sample. In **outdoor air** mode, “OA” will appear on the display along with the current reading on the bottom line. Previously taken values will display on the top line, or if this is the first time this mode has been used, “----” will display on the top line.

Press the SAMPLE key once the reading has stabilized in the outdoor location. The sampled value for outdoor air will display on the top line with the current reading on the bottom line. If the sample is not acceptable or the reading is not yet stable, wait a minute and then take another sample to overwrite the value on the top line. Once the value is acceptable, press the ▲ key to advance to supply air mode.

Move to the appropriate location for a supply sample and insert the probe into the supply duct. In **supply** mode, “SUPPLY” will appear on the display along with the current reading on the bottom line and “----” on the top line. Previously taken values will display on the top line, or if this is the first time this mode has been used, “----” will display on the top line.

Press the SAMPLE key once the reading has stabilized. The sampled value for supply air will display on the top line with the current reading on the bottom line. If the sample is not acceptable or the reading is not yet stable, wait a minute and then take another sample to overwrite the value on the top line. Once the value is acceptable, press the ▲ key to advance to %OA mode.

“OA%” will appear on the display along with the % outdoor air value. Press the SAMPLE key while in this mode to put all four samples into memory.

Note: “OA Err” means that the calculation does not make sense with the values stored. Retake all 3 measurements or use another parameter to measure %OA.

To make changes to one of the other three readings without putting them to memory, move to the appropriate location where the sample was taken, press the ▲ or ▼ keys to review the values and press SAMPLE to overwrite values if necessary.

To make another % outdoor air calculation, make sure you pressed SAMPLE to save your current values. Then use ▲ and ▼ to review the measurements and take new samples for supply and return. If you suspect the outdoor air value has changed, you will have to retake that sample as well.

When To Use CO₂ or Temperature To Calculate % Outdoor Air

Percent outdoor air can be calculated using either CO₂ or using temperature. There are some benefits to both of these methods and it's important to understand when to use one over the other.

Generally, CO₂ should be used when the building that you are interested in has a lot of occupants. This ensures that the CO₂ concentration values of outdoor air and return air are far apart. If there are a sufficient number of occupants then outdoor air should always be the lowest value, and return air should always be the highest. The further these two values are apart, the more accurate the %OA value will be. If there are few or no occupants, then there is little accumulation of CO₂ and the accuracy will not be as good.

Similarly, temperature should be used when the building or room of interest has a big difference in temperature from outdoor air temperatures. This means when it is hot or when it is cold outdoors, then it is a good time to use temperature as a means to calculate %OA. To take a temperature calculated %OA value, take the measurements at the Air Handling Unit. This means that the measurement will indicate the %OA for an entire area of the building, or the entire building depending on what area or areas the air handling unit serves. The reason the measurements need to be taken at the air handling unit is because there are often heating or cooling coils in the ducts or near the diffusers in some buildings which would adversely affect the readings and it is difficult to verify if they are present or not.

What Are Acceptable %OA Values

This is a popular question and it does not have an easy answer. There is no ideal %OA value because it depends on the air flow. If your air flow is high for the number of occupants, you may not need a high %OA. For instance, if you are delivering 1,000 CFM and there are 10 occupants in an office area, you would only need 20% OA to achieve the ASHRAE recommended 20 CFM/person.

$$(1,000\text{CFM} \times 20\%\text{OA}) / 10 \text{ people} = 20\text{CFM/person}$$

However, if you are only delivering 250 CFM in this same scenario with 10 occupants in the same office area, you would need 80% OA to achieve the 20 CFM/person recommendation.

$$(250\text{CFM} \times 80\%\text{OA}) / 10 \text{ people} = 20 \text{ CFM/person}$$

There is no easy answer to this question because the answer varies with the air flow and the maximum number of occupants. The best thing to do is to measure the air flow and find the maximum number of people that will be in the room. Then the following equation can be used to find the %OA that would be needed:

$$\%OA = (\text{CFM/person OA recommended} \times \text{maximum number of occupants}) / \text{air flow}$$

As an example, consider an office space where 20 CFM/person of outdoor air is recommended, where the maximum number of occupants is 30 and the air flow is 1,800 CFM:

$$\%OA \text{ recommended} = (20 \text{ CFM/person} \times 30) / 1,800 \text{ CFM} = 33.3\% \text{ outdoor air recommended}$$

Conclusion

To determine whether a building meets current ASHRAE recommendations of Outdoor Air, measure the volume of air entering a space as well as the %OA. Perhaps the easiest way to measure %OA is to take three samples of supply air, return air and outdoor air and to plug them into the given equation. TSI instruments will automatically do this calculation to save time. TSI was the first company to make instruments to do this calculation automatically and TSI continues to create and improve its instruments to meet the needs of the market.

References

¹TSI Application Note Traversing a Duct to Determine Average Air Velocity or Volume. TI-106.

Trademarks

TSI, TSI logo, VELOCICALC, DP-CALC, ACCUBALANCE, IAQ-CALC, and TH-CALC are trademarks of TSI Incorporated.

TSI Incorporated – 500 Cardigan Road, Shoreview, MN 55126 U.S.A

USA	Tel: +1 800 874 2811	E-mail: info@tsi.com	Website: www.tsi.com
UK	Tel: +44 149 4 459200	E-mail: tsiuk@tsi.com	Website: www.tsiinc.co.uk
France	Tel: +33 491 11 87 64	E-mail: tsifrance@tsi.com	Website: www.tsiinc.fr
Germany	Tel: +49 241 523030	E-mail: tsigmbh@tsi.com	Website: www.tsiinc.de
India	Tel: +91 80 41132470	E-mail: tsi-india@tsi.com	
China	Tel: +86 10 8260 1595	E-mail: tsibeijing@tsi.com	
Singapore	Tel: +65 6595 6388	E-mail: tsi-singapore@tsi.com	



TRUST. SCIENCE. INNOVATION.

Contact your local TSI Distributor or visit our website www.tsi.com for more detailed specifications.