

Nanotechnology

Sampling and Conditioning

Application Note PR-002

Nanoparticle Formation & Processing

Nanomaterials have novel electrical, catalytic, magnetic, mechanical, thermal, and optical properties. The types of processing techniques used to create them are as varied as the types of nanoparticles that are created. Nanoparticle synthesis can be divided into two general categories: gas synthesis and wet synthesis. The choice of gas vs. wet is often based on the type of nanoparticle being created. In many cases however, both options are viable for the nanoparticle of interest (i.e., carbon nanotubes, TiO₂, FeO).

Gas Synthesis

In gas phase synthesis, the nanoparticle formation reaction takes place in a gas. Typically precursors are gaseous, but they can also be solid (furnace reactors) or aerosol (particles suspended in a gas). Some of the most popular synthesis schemes and some researchers who did influential early work on these techniques is listed below.

Gas Synthesis Technique	Early Research Contributors
Evaporation & Condensation	Gleiter 1989, Siegel 1991, 1994
Combustion Flame	Zachariah 1994, Calcoste & Keil 1997, Axelbaum 1997, Pratsinis 1997
Plasma	Rao et al. 1997
Laser Ablation	Becker et al. 1997
Chemical Vapor condensation	Kear et al. 1997
Spray pyrolysis	Messing et al. 1994
Electrospray	de la Mora et al. 1994
Plasma Spray	Berndt et al. 1997
Micro Plasma	Sankaran 2007

Table 1: Popular gas synthesis schemes and influential researchers

Advantages of Gas Phase Synthesis

Gas phase reactions are often more easily controlled and so a higher level of **monodispersity** can frequently be achieved. These reactions can also have quite **short process chains**—with just a few process steps needed to produce to final product. Additionally, many of these reactions are almost instantaneous, so they boast **very short process times**. Frequently gas phase synthesis has measurably **reduced costs** versus comparable wet synthesis schemes. One of the most impactful advantages to gas phase synthesis is the greatly reduced amount of environmental waste. It is predominantly the **greener process** choice. Another powerful advantage is that gas phase synthesis more readily lends itself to the immediate feedback of **on-line aerosol measurement techniques**.

On-line Aerosol Measurements

On-line aerosol measurements are a powerful tool in nanoparticle synthesis whether you are a researcher, process engineer or in charge of nanoparticle quality control. **Real time feedback** can significantly speed up both product and process R&D timelines and can let you know sooner rather than later if your process has gotten out of control and you are producing junk product. Nanoparticle manufacturing is very similar to the semiconductor industry in that time is quite literally money due to the extreme value of the manufactured product. If measurements for product quality feedback take two days using an off line technique, that is a risk of two days worth of manufactured product. An added bonus: on-line measurements are frequently far more **cost effective** than expensive off line surface imaging schemes.

On-line Measurement Tools	Metric
Condensation Particle Counter (CPC) or Water-Based CPC (WCPC)	Total nanoparticle concentration (particles/cm ³)
Scanning Mobility Particle Sizer™ (SMPS™) Spectrometer	Size distribution (30s, 152 channel resolution)
Fast Mobility Particle Sizer™ Spectrometer	Size distribution (1s, 52 channel resolution)
Nanoparticle Surface Area Monitor	Nanoparticle surface area (μm ² /cm ³)

Sampling and Conditioning Challenges

Nanoparticle processing schemes can present challenging sampling environments: high temperatures, low pressures, high concentrations, and a variety of gas types. Yet most on-line measurement techniques require the sample to be at or near STP^a and the sample to be aerosolized in air. From Table 1 you can see that gas synthesis schemes are widely variable, so a one size fits all sample and conditioning solution is not available. However, early nanoparticle gas synthesis research innovators have successfully designed solutions for many different sampling environments, and their published work can pave the way for contemporaries interested in utilizing on-line techniques.

Low Pressure Sampling

Investigators have successfully used TSI sizers and counters to sample from low pressure environments for decades. One early example is Evan Whitby (son of one of the fathers of aerosol science Ken Whitby). In 1995 he collaborated with Hitachi to sample from a CVD chamber at approximately 100Pa (0.75Torr) and measure total concentration on-line using a Condensation Particle Counter (CPC)¹. A schematic of his low pressure sampler and the process steps are detailed below. In general, low pressure sampling utilizes one of two schemes: 1) volume evacuation and 2) ejection diluter.

^a Standard Temperature and Pressure (STP), US: $P_{std} = 101.4$ kPa; $T_{std} = 294.3$ K, EURO; $P_{std} = 101.33$ kPa; $T_{std} = 273.2$ K

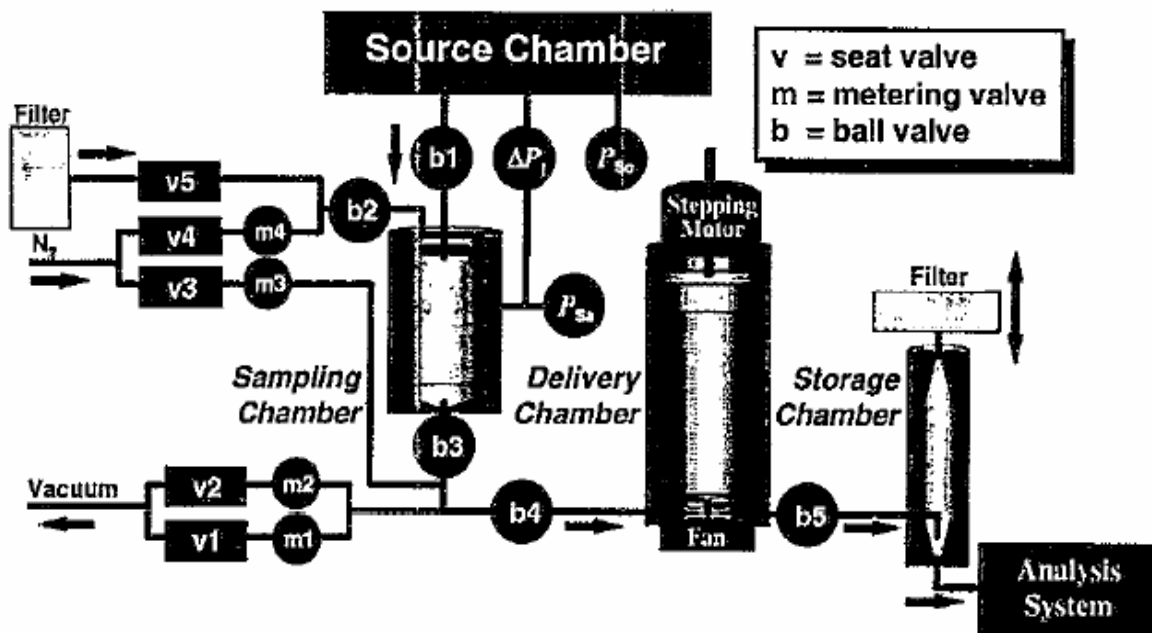

Figure 1: Low-pressure Aerosol Sample (taken from original paper published in 1995)¹.

Process Steps

1. Sampling chamber (P_{sa}) reduced below source chamber (P_{so}).
2. Aerosol sampled until $P_{sa} = P_{so}$
3. P_{sa} raised to atmospheric
4. Aerosol transferred to delivery chamber
5. Aerosol moved to storage change at steady flow rate Q_D
6. Aerosol sampled from storage change at Q_A

Volume Evacuation

This technique is used by several large nanoparticle manufacturers to sample products throughout the synthesis process and characterize them in real time using on-line aerosol measurement tools. The volume evacuation process is almost identical to the process flow of Whitby's sampler. A sample chamber is evacuated—brought down to a slightly lower pressure than the source chamber. A valve connecting the chambers is opened. The drive to equalize the pressure difference forces aerosol into the sample chamber and when sampling is finished, the valve is closed. The sample chamber is then pressurized in a controlled manner. Once the chamber reaches near atmospheric pressure, a CPC, Scanning Mobility Particle Sizer™ (SMPS™) Spectrometer or other on-line measurement instrument can be used. In this approach, the chambers are static and have a fixed volume. Sampling from a static volume can cause pressure problems unless some complex approaches are used to equalize the pressure (as in Whitby's schematic). To overcome this, a foil bag is frequently used. The bag volume can expand and contract as necessary, making static sampling more straightforward.

Low Pressure Sampler for SMPS™ Spectrometer

Figure 2 is from the work of Ober et al² published in 2002. The low-pressure system detailed in the paper was designed specifically to interface with a SMPS™ system. Ober expanded on the work of Whitby and used a variable volume bag technique. Ober's system was optimized to minimize particle losses and the efficiency of the system was characterized.

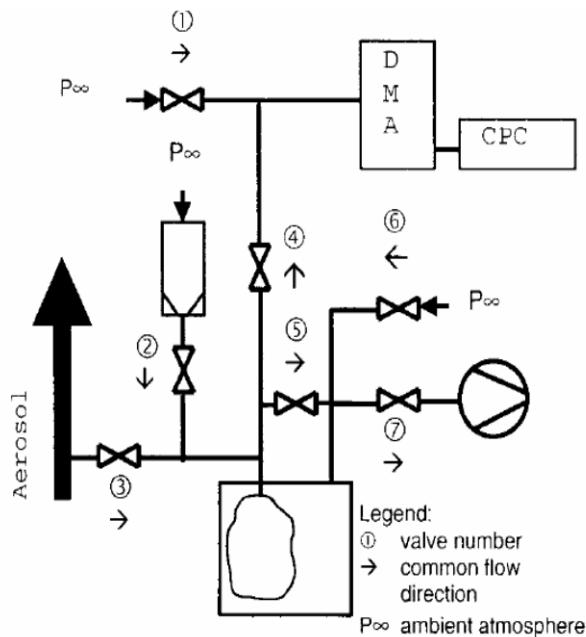

Process Steps

1. Evacuate foil bag
2. Reduce bag pressure below sample pressure
3. Sample (driven by pressure differential)
4. Optional Dilution
5. Transfer to ambient pressure
6. Measure size distribution using SMPS™ Spectrometer

Figure 2: Low-pressure sampling device (LSPD). Taken from original paper published in 2002.

Low Pressure Sampling - Ejection Diluter

Another commonly used method to sample from low pressures is to use an ejection diluter. This approach has the added benefit of being able to quickly cool and dilute the sample. Wang et al³ implemented this solution to sample from a thermal plasma process reactor operating at ~266Pa with an operating temperature range of 2000 to 4000K. A water-cooled molybdenum capillary probe was used to extract the sample from the high temperature environment. The system integrated a two-stage ejector diluter (Air-Vac UV143H – commercially available) and used nitrogen as the compressed air source. The 1st stage of dilution on the ejector diluter is determined by the nitrogen flow rate and the pressure of the sample chamber. The 2nd stage dilution is controlled by the aerosol flow through the flowmeter.

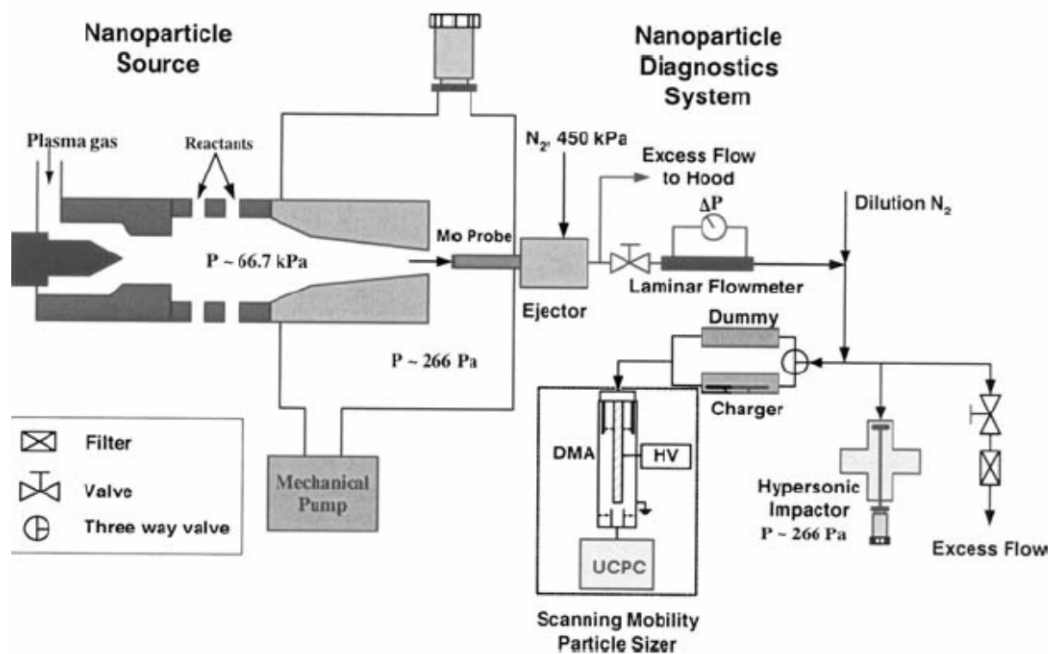

Figure 3: Schematic diagram of Wang et al³ low pressure, high temperature sampling system. Taken from original paper published in 2005.

Wang et al's system was also designed to reduce changes in the sampled aerosol size distribution. The short sample residence time significantly reduces diffusion losses and the nitrogen dilution reduces coagulation losses. Even though there will be some unavoidable thermophoretic losses due to the extreme temperature differential, Wang et al determined below 200nm the thermophoretic losses are not size dependent, so the size distribution will not be skewed.

High Temperature and High Concentrations

As detailed above, an **ejector dilutor** can be used to reduce temperature and concentration. Another option is to use the **Rotating Disk Thermal Dilutor** (Model 379020-30A) with a thermal conditioner. The dilution ratio and the sampling temperature can be carefully controlled using this technique.

Process Gas Type

In nanoparticle gas synthesis processes, a variety of process gases are used. However, most on-line aerosol techniques are designed to function only with air as the working gas. Two solutions to this problem are: 1) convert the carrier process gas surrounding the nanoparticles to air or N_2 , or 2) use the aerosol measurement technique with a different working gas (typically not recommended by the manufacturer). The second option is only available for inert working gases and requires more investigation and experimentation on the part of the investigator. Converting the carrier gas to N_2 or air is generally the best option.

DMA as a Gas Converter

Many nanoparticle process schemes already incorporate some method of converting carrier gases. One novel method detailed by Myoyo et al⁴ is to use a Differential Mobility Analyzer (DMA) as a gas converter.

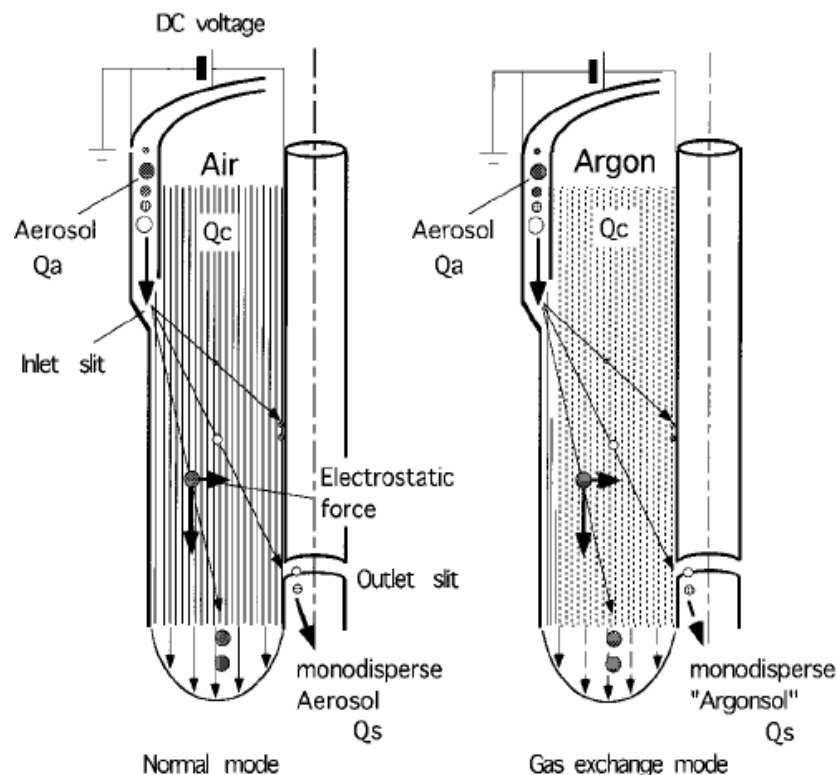

Figure 4: Conceptual diagram of DMA gas-exchange method. Taken from original paper published in 2002.

Due to the DMA flow design, when operated using the standard re-circulating sheath air scheme, eventually the DMA sheath gas will become the carrier sample gas of the DMA. This is because there is never a new source of sheath gas—the flow is re-circulating. If the DMA is used in non-recalculating mode, the aerosol exiting the

sample stream from the DMA will be primarily composed of the sheath gas. In this configuration a DMA can be used as a gas converter. This modification requires an independent sheath air source, and independent control of 3 of the 4 flows in the DMA: sheath flow rate, excess flow rate, polydisperse flow rate and monodisperse sample flow rate.

Inert Gases (N₂, Ar, He, CO₂, N₂, N₂O)

If the process gases being used are for the most part inert, some researchers have successfully used CPCs and SMPST[™] spectrometers (which uses a DMA for sizing) in other working gases. Schmid et al⁵ investigated DMA accuracy using He, Ar, CO₂ and N₂O and concluded that when properly calibrated, there was no effect of gas type on the accuracy of the DMA. Karg et al⁶ also studied the effect gas composition and relative humidity on the performance of a DMA. Niida et al⁷ investigated the counting efficiency of CPCs using N₂, Ar, CO₂ and He and noted slight efficiency curve differences. The noted differences were quite small and for the most part effected measurements below 10nm.

The Aerosol Instrument Manager[®] software for the SMPS[™] spectrometer allows input of **gas viscosity** and **mean free path**. However, when switching working gases, other variables need to be considered as well. The internal flowmeters in the DMA and CPC are calibrated using air. If other gases are used, it is important that the **flow rates** of the DMA and CPC be calibrated using an independent volumetric flowmeter. In the DMA there is also an issue concerning electrical breakdown. At high voltages, electrical arcing can occur within the DMA which limits the upper range of the DMA. Meek and Craggs⁸ looked at **breakdown voltage** (V_b) for different gas types. Schmid found that noble gases have V_b of about an order of magnitude smaller than air. This will effectively limit the upper size range of the measurement.

Wet Synthesis

In wet synthesis nanoparticle processing, the nanoparticle formation reaction takes place in a liquid. A precipitation agent is added to a liquid precursor. The primary process control parameters for this type of process are the chemistry of the solution and the temperature and pressure treatment of the mixture.

Wet Synthesis Advantages

Wet processing is frequently used because it is a **mature technology**. The precursors and process set-points are well known and the processes have a **high degree of repeatability**. There are also a large number of liquid based characterization tools available. On-line aerosol techniques can also be used for many wet synthesis applications if the nanoparticle product can be aerosolized.

Aerosolization of Wet Synthesis Product

If the nanoparticle product is in an aqueous solution, or if it can be transferred to an aqueous solution, the Electropray Aerosol Generator (EAG – Model 3480) can be used to aerosol the product. Böttger et al⁹ from Lund University in Sweden successfully electrosprayed colloidal gold particles and measured them with the SMPS[™] Spectrometer. SiO₂, TiO₂ and other nanomaterials have also been successfully aerosolized and subsequently characterized with on-line aerosol measurement techniques.

References

- ¹Whitby, Evan; Hoshino, Masakazu, 1995 “Development of a low-pressure aerosol sampler,” *Review of Scientific Instruments* **66** (7) 3955-3965
- ²Ober, Frank; Mayer, Michael, Büttner, Ebert, Fritz, 2002 “Aerosol Measurement in Low-Pressure Systems with Standard Scanning Mobility Particle Sizers,” *Particle & Particle Systems Characterization*, **19**, 229-239.
- ³Wang, X., Hafiz, J., Mukherjee, R., Renault, T., Heberlein, J., Girshick, S.L., McMurry, P.H., 2005 “System for In Situ Characterization of Nanoparticles Synthesized in a Thermal Plasma Process,” *Plasma Chemistry and Plasma Processing*, **25** (5), 439-453.
- ⁴Myoyo, Toshihiko; Mitsutoshi, Takaya; Ono-Ogasawara, Mariko, 2002, “DMA as a Gas Converter from Aerosol to “Argonol” for Real-Time Chemical Analysis Using ICP-MS”. *Aerosol Science and Technology* **36**: 76-83
- ⁵E. Karg, S. Dua, G. Ferron, “Performance of a Differential Mobility Analyzer at Different Gas Compositions,” *Aerosol Science*, **23**(S1):S389-S392, 1992.
- ⁶O. Schmid, M. Tureblood, N.Gregg, D.Hagen, P. Whitefield, “Sizing of Aerosol in Gases Other Than Air Using a Differential Mobility Analyzer,” *Aerosol Sci. & Tech.* **36**:351-360, 2002
- ⁷T. Niida, H Wen, R. Udischas, G. Kasper, “Counting Efficiency of Condensation Nuclei Counters in N₂, Ar, CO₂ and He,” *J. Aerosol Sci.* **19**:7,1417-1420, 1988.
- ⁸J.M Meek, J.D. Craggs, “Electrical Breakdown of Gases,” John Wiley, Chichester, 1978.
- ⁹Böttger, M., Bi, Z., Adolph, D., Dick, K., Karlsson, L., Karlsson, M., Wacaser, A., Deppert, K., 2007 “Electrospraying of Colloidal Nanoparticles for Seeding Nanostructure Growth” *Nanotechnology* (**18**) 105304 (6pp)

TSI Incorporated – 500 Cardigan Road, Shoreview, MN 55126 U.S.A

USA	Tel: +1 800 874 2811	E-mail: particle@tsi.com	Website: www.tsi.com
UK	Tel: +44 149 4 459200	E-mail: tsiuk@tsi.com	Website: www.tsiinc.co.uk
France	Tel: +33 491 11 87 64	E-mail: tsifrance@tsi.com	Website: www.tsiinc.fr
Germany	Tel: +49 241 523030	E-mail: tsigmbh@tsi.com	Website: www.tsiinc.de
India	Tel: +91 80 41132470	E-mail: tsi-india@tsi.com	
China	Tel: +86 10 8260 1595	E-mail: tsibeijing@tsi.com	
Singapore	Tel: +65 6595 6388	E-mail: tsi-singapore@tsi.com	



TRUST. SCIENCE. INNOVATION.

Contact your local TSI Distributor or visit our website www.tsi.com for more detailed specifications.